

MVS4500-LV

MV Turnkey Solution for 1500 Vdc String Inverter SG320HX-20



SAVED INVESTMENT

- Up to 5.25 MW block design
- Easy transportation due to standard container design
- All pre-assembled for easy set-up and commissioning



EASY O&M

- Online analysis for fast trouble shooting
- Modular design, main device easy replacement



SAFETY

- MV and LV isolated, independent control room
- All key components front accessible, no need walk-in operation



RELIABLE

- All components type-tested
- Compliance with standards: IEC 60076, IEC 62271, IEC 61439

CIRCUIT DIAGRAM

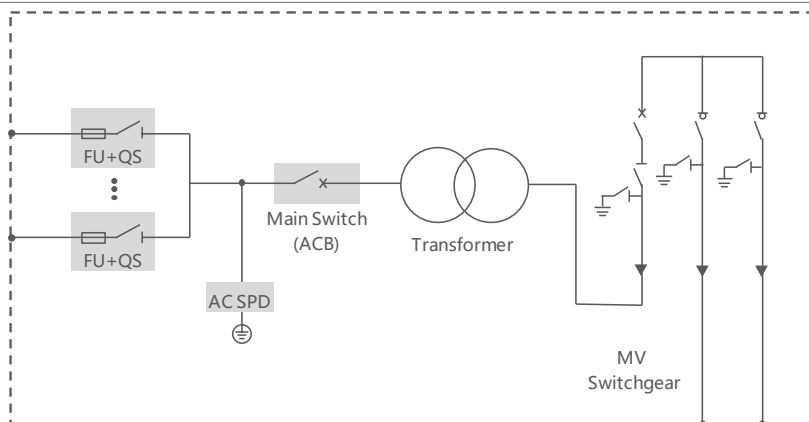

Type designation	MVS4500-LV
Transformer	
Transformer type	Oil immersed
Rated power	4500 kVA @ 51 °C , 4527 kVA @ 50 °C
Max. power	5280 kVA @ 30 °C
Vector group	Dy11
LV / MV voltage	0.8 kV / (10 - 35) kV
Maximum input current at nominal voltage	3811 A
Frequency	50 Hz / 60 Hz
Tapping on HV	0 , ± 2 * 2.5 %
Efficiency	≥ 99 %
Cooling method	ONAN (Oil Natural Air Natural)
Impedance	8 % (± 10 %)
Oil type	Mineral oil (PCB free)
Winding material	Al / Al
Insulation class	A
MV switchgear	
Insulation type	SF6
Rated voltage range	24 kV – 40.5 kV
Rated current	630 A
Internal arcing fault	IAC AFL 20 kA / 1 s
LV panel	
Main switch specification	4000 A / 800 Vac / 3P, 1 pcs
Disconnecter specification	260A / 800 Vac / 3P, 15 pcs
Fuse specification	400A / 800 Vac / 1P, 45 pcs
Protection	
AC input protection	Fuse+Disconnecter
Transformer protection	Oil-temperature, Oil-level, Oil-pressure, Buchholz
Relay protection	50 / 51 , 50 N / 51 N
Surge protection	AC Type I + II
General data	
Dimensions (W * H * D)	6058 mm * 2896 mm * 2438 mm
Approximate weight	17 T
Operating ambient temperature range *	-20 °C to 60 °C (optional: -30 °C to 60 °C)
Auxiliary power supply	15 kVA / 400 V (optional: max. 40 kVA)
Degree of protection	IP54
Allowable relative humidity range (non-condensing)	0 % – 95 %
Operating altitude	1000 m (standard) / > 1000 m (optional)
Communication	Standard: RS485, Ethernet, Optical fiber
Compliance	IEC 60076, IEC 62271-200, IEC 62271-202, IEC 61439-1, EN 50588-1

* The ambient temperature is determined as the average temperature obtained from at least four evenly distributed temperature monitoring points located at a distance of 1 meter from the equipment, at a height halfway up the machine. The temperature sensors must be shielded from airflow, thermal radiation, and rapid temperature fluctuations to prevent display inaccuracies.